



Installation Guide

includes:

- > pc
- > i/o devices
- > installation guide
- > getting started instructions



climate automation systems

Saving the Earth One Kilowatt at a Time.

© 2008 Climate Automation Systems.

All Rights Reserved. No part of this document may be photocopied, reproduced, stored in a retrieval system, or transmitted, in any form or by any means whether, electronic, mechanical, or otherwise without the prior written permission of Climate Automation Systems.

No warranty of accuracy is given concerning the contents of the information contained in this publication. To the extent permitted by law no liability (including liability to any person by reason of negligence) will be accepted by Climate Automation Systems, its subsidiaries or employees for any direct or indirect loss or damage caused by omissions from or inaccuracies in this document.

Climate Automation Systems reserves the right to change details in this publication without notice.

Windows is a trademark and Microsoft, MS-DOS, and Windows NT are registered trademarks of Microsoft Corporation. Other product and company names herein may be the trademarks of their respective owners.

Climate Automation Systems
404.831.2762
gogreenwithENV.com

Table of Contents

1	About this Guide	4
	Audience	4
	Scope	4
	Typographical conventions	4
2	Overview of the System	5
	System architecture	5
	Prerequisites to installation	6
3	Installing the Input/Output Module	7
	Installation location	7
	Mounting the I/O module.....	7
	Connecting power to the I/O module	7
4	Installing the VLinx Serial Server	9
	Mounting the VLinx serial server	9
	Connecting power to the VLinx serial server	9
	Connecting the VLinx serial server to the network	9
	Configuring the VLinx serial server	9
5	Installing Thermostats.....	11
	Installing a communicating thermostat	11
6	Communication Wiring.....	12
	Communication wiring options	Error! Bookmark not defined.
	Communication wiring for Ethernet to VLinx serial server to I/O module	Error! Bookmark not defined.
	Communication wiring using a USB to RS485 converter	Error! Bookmark not defined.
7	Wiring Equipment to the I/O Module.....	13
	Wiring analog and digital inputs	13
	Wiring digital outputs.....	14
	Wiring analog outputs	18
8	Supported Sensors and Control Devices.....	19

1 About this Guide

This guide provides the instructions for installing and configuring Climate Automation Systems' **ENV** climate control system.

Audience

This guide is intended for control contractors and mechanical contractors who install the components of the **ENV** climate control system including sensors and field wires.

This guide assumes that you have some knowledge of basic low-voltage electrical wiring.

Scope

This guide provides all the information you need to install, configure, and start running the **ENV** climate control system.

Typographical conventions

This document uses the following typographical conventions:

- Command and option names appear in bold type in definitions and examples. The names of directories, files, machines, partitions, and volumes also appear in bold.
- Variable information appears in italic type. This includes user-supplied information on command lines.
- Screen output and code samples appear in monospace type.

In addition, the following symbols appear in command syntax definitions.

- Square brackets [] surround optional items.
- Angle brackets < > surround user-supplied values.

2 Overview of the System

ENV is an energy management system that controls, manages, and monitors all aspect of a building's environment. ENV is the first system of its kind to take intelligent climate control technologies and bring them to the residential and commercial market. ENV uses real-time weather information and the rules of a sustainable ENVironment to control any device in the building or mechanical room (regardless of the manufacturer) to balance all aspects of the building's ENVironment and create the ideal climate for comfort, human well being, and energy reduction.

System architecture

The ENV software runs on a computer running Microsoft® Windows™ Vista Business.

The following diagram illustrates a typical installation of an ENV.

1. All devices being monitored or controlled are wired directly into an IO block, which is an A/D convertor. The wiring to the IO block is low voltage. So, to switch a high voltage device on and off, a relay must be used. Each IO block has a set of IO points to which the wires connect. Each point has a unique address within each IO block.
2. The IO blocks are interconnected and daisy chained to the VLINX device which converts a RS485 serial signal to Ethernet. In this way, the IO blocks are IP addressable and can be seen from anywhere on the intranet.
3. If a forced air system is to be controlled by ENV, communicating thermostats are used. The thermostats use four wires from the wall mount into the mechanical room to a control device that comes with each thermostat. The control device is wired directly to the appropriate air handler or heat pump. In this manner, the thermostats function as ordinary thermostats.

Each of the thermostats' control device has a pair of wires that communicate RS 485 and daisy chain and connect to the VLINX just like the IO block. They can daisey chain through the IO block but that is not a requirement.

4. The VLINK is connected to a router or to switch within the building. In this way the VLINX is visible on the intranet.
5. The PC is also connected to the intranet within the building and is able to communicate with all of the IO blocks and with the thermostats via Ethernet.

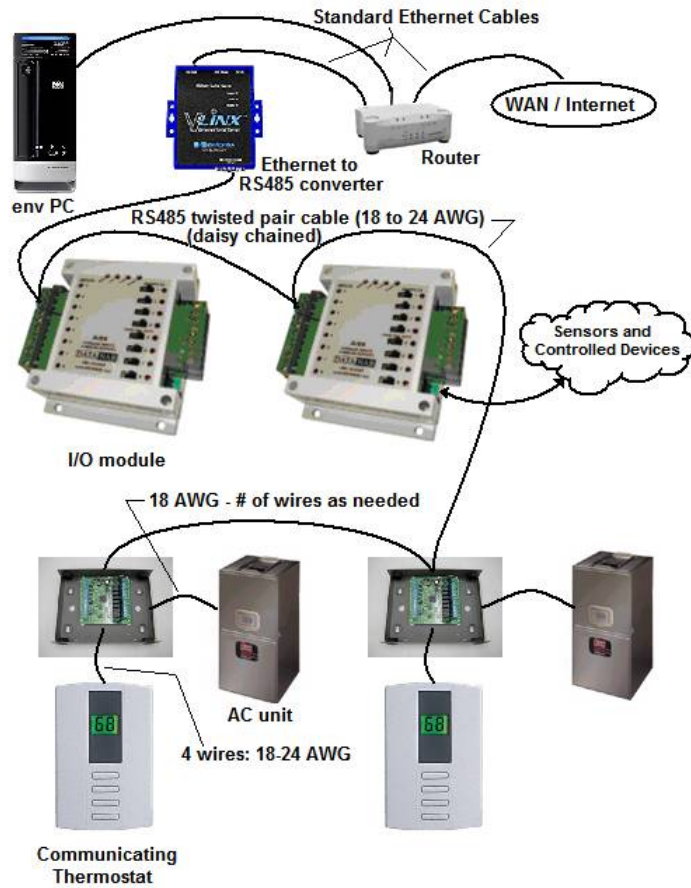

Prerequisites to installation

Before you begin installation of the ENV climate control system, ensure the following are available:

- an active external network connection
- a router

3 Installing the Input/Output Module

The ENV climate control system uses one or more input/output modules to interface with the climate control devices. Currently, the following Modbus-compatible DataNab input/output modules are certified for use with the ENV system:

Module	Analog Inputs	Analog Outputs	Digital Inputs	Digital Outputs	Pulse Counter	Comment
Ai8_R13	8 ¹		8	13 ²	Yes ³	A total of 8 universal inputs (analog, digital, or counter - max. rate is 100 Hz) and 13 Digital Outputs.
AiO8	8 ¹	8 ⁴	8		No	8 universal inputs (analog or digital) and 8 analog outputs which can drive 0-10 volt analog devices or external relays.
Ai32	32 ¹		32		No	32 universal inputs (analog or digital)

1. Digital input may be a dry contact or an NPN open collector transistor (jumper set to thermistor) or external voltage (0v=off, 5v =on).
Analog inputs may be directly connected thermistors, 0-5 volts or 0-20 milliamps (internal jumper selectable per input).
2. Outputs are isolated normally open single pole contacts.
3. Any input can also be a high speed counter in an Ai8_R13 only. Input must be a dry contact or an NPN open collector transistor - 100Hz maximum.
4. The AiO8 can drive relays for use as a digital output as well as provide a 0-10 volt output.

Installation location

Mount the module in a low-voltage enclosed panel.

Environmental operating range:

- 50° to 99° F (10° to 50° C)
- Relative humidity should be 10% to 90%, non-condensing

Mounting the I/O module

Mount the modules in one of the following ways:

- using a DIN rail (preferred for quick change-outs)
- using four screws and the mounting holes provided on the cover plate

Be sure to leave space either side of the module for wiring.



Connecting power to the I/O module

Each DataNab I/O module consumes about 100 milliamps; take care not to exceed the power supply rating based on the number of devices plus any auxiliary relays or externally powered sensors that use the same power.

Power requirement is typically 12 to 24 volts DC or AC.

Note: An AiO8 must be powered with 24 volts DC or AC to achieve full voltage (10 volts DC) on the analog outputs.

To connect power:

1. Make sure that the power source is off.
2. Connect the power wires to the module's lower power terminals labeled 24VAC and . If using a DC power supply, connect the positive (+) wire to the 24VAC terminal and the negative (-) wire to the  terminal.

Caution: When wiring an Ai8_R13, make sure you connect power to the correct terminals.
DO NOT connect to the upper terminals labelled POWER.

Note: When using more than one module, you can daisy-chain the power wiring between modules.

3. Plug in the wall-plug power supply.
4. If the Power LED on the I/O module does not come on, make sure that power is present at the module's power input terminals and that polarity (if DC) is correct.

4 Installing the VLinx Serial Server

The preferred PC to I/O module communication option requires a VLinx serial server. This section will guide you through installing the Ethernet to RS485 serial server.

Mounting the VLinx serial server

Mount the VLinx serial server into the same enclosed panel as the I/O module in one of the following ways:

- using a DIN rail (preferred for quick change-outs)
- using four screws and the mounting holes provided on the cover plate

Be sure to leave space on either side for wiring.

Connecting power to the VLinx serial server

To connect power to the VLinx serial server:

1. Set the DIP switches on the VLinx serial server to the OFF position.
2. Connect the power cable to the DC-IN jack on the top of the VLinx serial server.
3. Plug in the wall-plug power supply.
4. If the Power LED is not lit, make sure that 12VDC is present at the power input terminal.

Connecting the VLinx serial server to the network

To connect power to the VLinx serial server:

1. Connect one end of a standard Ethernet network cable to the VLinx serial server.
2. Connect the other end of the network cable to the router.

Configuring the VLinx serial server

To configure the VLinx serial server (match the settings illustrated in the figure below, i.e., Server Properties):

1. Download the VLinx documentation from http://www.bb-elec.com/product_family.asp?familyid=2.
2. Using the VLinx documentation and the VLINX software, set the VLinx serial server address to a unique network address. Typically this should be 192.168.1.91 but could vary based on the IP ranges used by the installed router.
3. Set the VLinx serial server port number to 4000.

Note: You can use any port number as long as you specify the correct port number when you configure the ENV climate control system software.

4. Set the serial communication parameters to 9600 baud, 8 data bits, and no parity.
5. Open the VLINX by removing the two screws on the side. You will see two jumpers on pin 78. Move them to the location shown below so that they are placed across the two pins in each of the two locations.

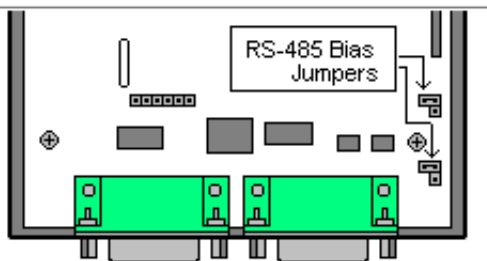

Server Properties

B&B Electronics
VLINX ESP901

Server name:	<input type="text" value="1_Port"/>	Serial port:	<input type="text" value="1"/>	Delimiter HEX 1:	<input type="text" value="00"/>
Serial number:	<input type="text" value="0910044073"/>	Baud rate:	<input type="text" value="9600"/>	Delimiter HEX 2:	<input type="text" value="00"/>
Password:	<input type="text"/>	Data/Stop bits:	<input type="text" value="8-1"/>	Force transmit:	<input type="text" value="0"/> x100ms (0-65535)
DHCP:	<input type="text" value="Disable"/>	Parity:	<input type="text" value="None"/>	Inter-Byte:	<input type="text" value="0"/> x100ms(0-65535)
IP address:	<input type="text" value="192.168.1.91"/>	Flow control:	<input type="text" value="None"/>	Port status:	<input type="text" value="Not Connected"/>
Netmask:	<input type="text" value="255.255.255.0"/>	Protocol:	<input type="text" value="TCP"/>	TCP/UDP port:	<input type="text" value="4000"/>
Gateway:	<input type="text" value="192.168.1.1"/>	Serial timeout:	<input type="text" value="5"/> (0-65535 sec)	Serial port mode:	<input type="text" value="RS485H"/>
MAC address:	<input type="text" value="00:08:B4:11:AC:29"/>	TCP alive timeout:	<input type="text" value="0"/> (0-255 min)	Connection:	<input type="text" value="Power up"/>
Version & Date:	<input type="text" value="2.0 & 01/31/08"/>	Connection mode:	<input type="text" value="Server"/>	Maximum connection:	<input type="text" value="1"/>
Link status:	<input type="text" value="100/Half Duplex"/>	Remote IP:	<input type="text" value="255.255.255.255"/>		
Hardware ID:	<input type="text" value="PCB-2318-P1"/>				

5 Installing Thermostats

Include a communicating thermostat as part of the system when managing a typical forced air heating and cooling system. You can also use a communicating thermostat to control a radiant heat zone where traditional readout and manual setpoint adjustment is still desired at that location.

Installing a communicating thermostat

Communicating thermostats provide a way for the controlling computer to manage traditional forced air thermostats through a browser interface. The number of zones will determine the quantity and type of communicating thermostats.

Climate Automation Systems has approved the Residential Control Systems, Inc. (<http://www.resconsys.com>) TR16 communicating thermostat for use with the ENV system. Refer to the RCS manuals found at <http://www.resconsys.com/products/stats/serial.htm> for installation instructions and for instructions on how to set a unique address for each thermostat.

Tie the communicating thermostats to the ENV system by connecting (daisy chaining) a pair of wires to the RS485 terminals of each thermostat and continue to other RS485 devices. Ultimately the pair of wires should terminate at the VLinx. A grounding wire should also be included and daisy chained throughout.

6 Communication Wiring

After you install the various components of the ENV climate control system, you must set up the communication wiring so the components can communicate with the PC.

To connect communication wiring:

1. Connect the VLinX converter to the network through a router or hub using a standard network cable.
2. Connect the VLinX serial server to the RS485 terminals on the I/O module using a 24 AWG to 18AWG twisted pair copper wire (you can also use raw Cat-5 cable) or you can purchase a 9Pin female cable from Radio Shack and cut off one end to expose the wires and trace them back to pins 3-5 as follows: Pin 3 is plus and pin 4 is minus and pin 5 is ground.

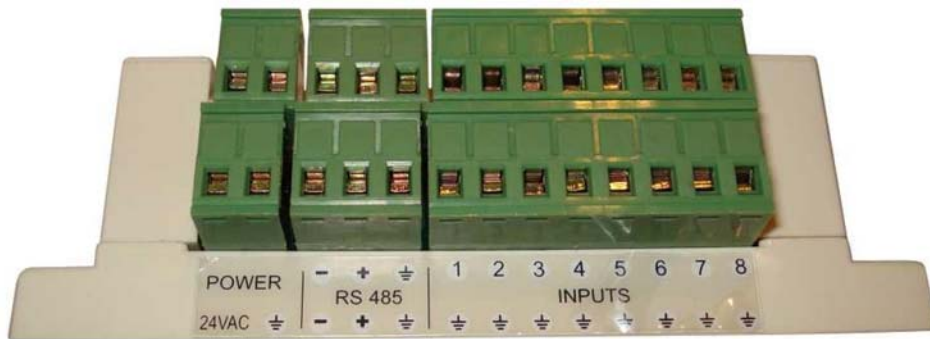

3. Connect the computer to the network through a router or hub using a standard network cable.

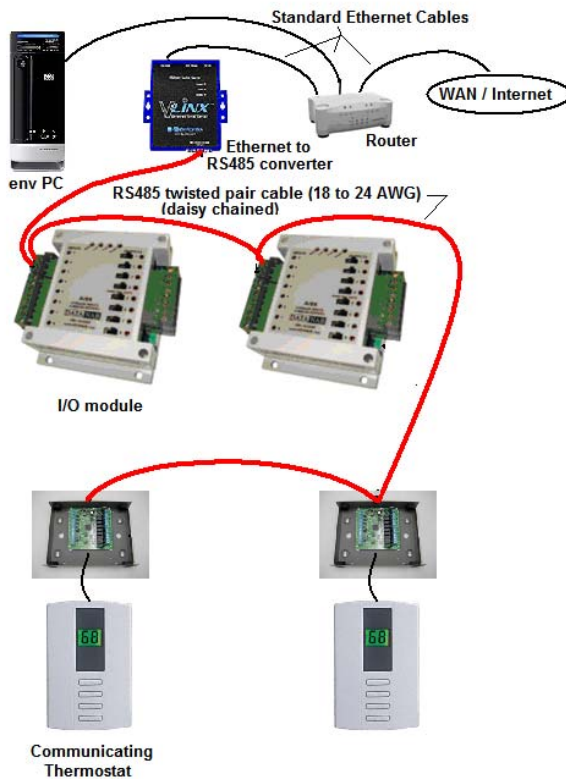

7 Wiring Equipment to the I/O Module

Use a maximum wire size of 18AWG for wiring inputs and outputs. A 22AWG wire is the recommended size for inputs.

If you must run analog signal wiring a long distance or through areas with electrical interference, use shielded wire. The shield should be connected to ground only at the panel end.

Wiring analog and digital inputs

You can wire analog and digital inputs to the following DataNab modules:

- Ai8_R13
- AiO8
- Ai32

Use analog inputs to monitor temperature, amps, or voltage. Typical analog sensors include thermistor based temperature sensors. The ENV system is capable of handling either a 10K Type II or a 10K Type III industry standard thermistor.

Use digital inputs to monitor status or alarms, such as damper position or a water sensor. Traditional digital inputs are either a dry contact or open collector transistor from a device.

To wire inputs:

1. Be sure the I/O module power is off before wiring any inputs.
2. Connect analog input wiring as follows:

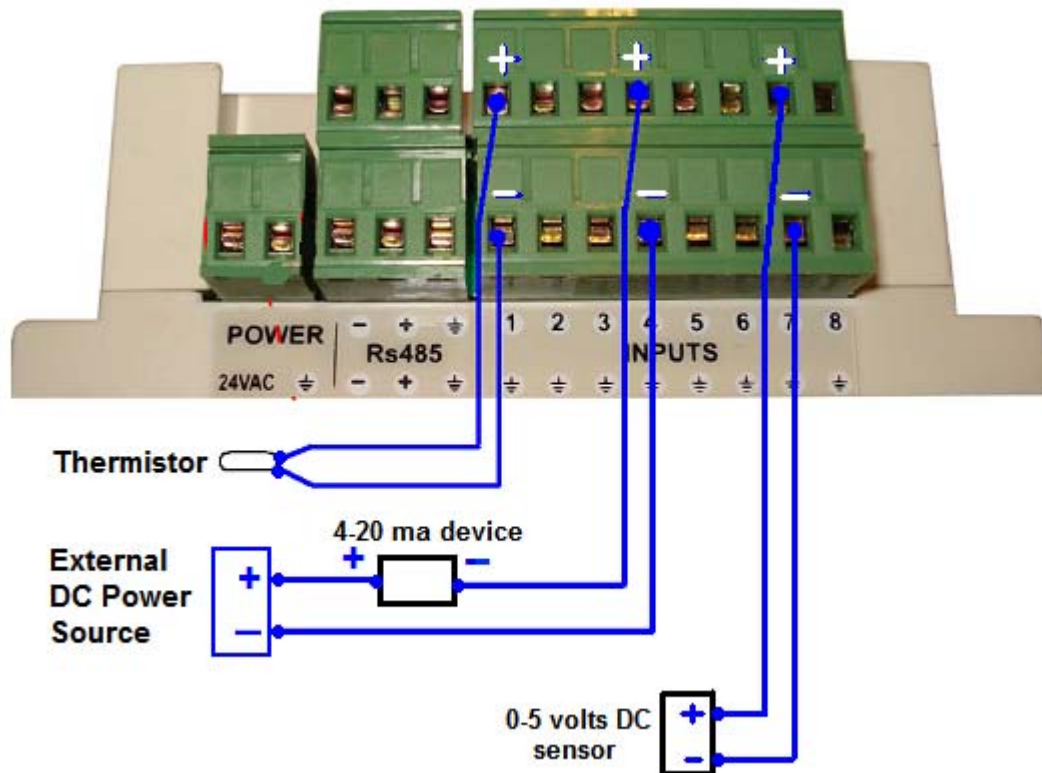

3. Connect digital input wiring as follows:

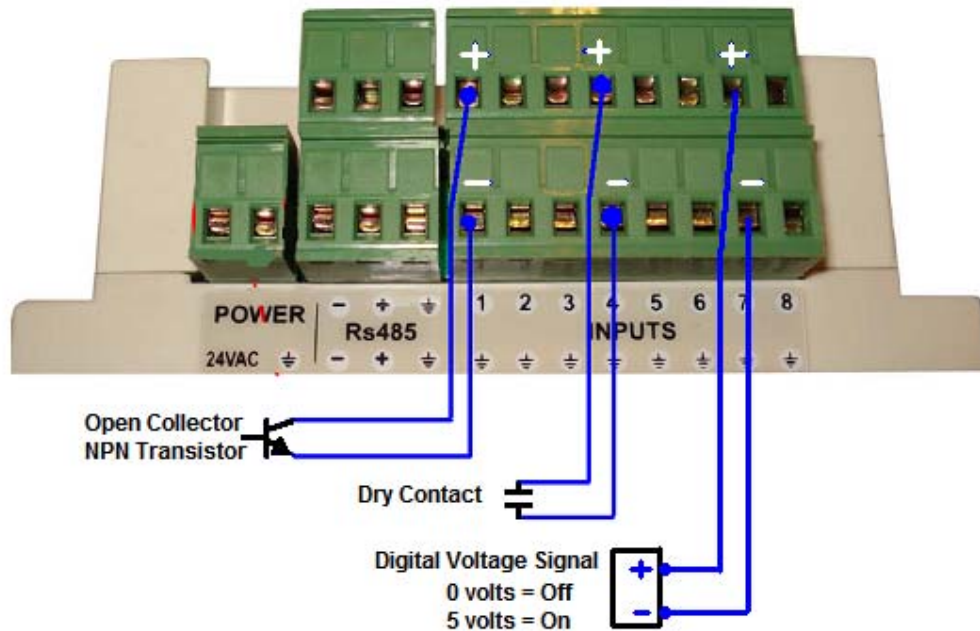

4. If the input is DC volts or milliamps, remove the module cover and set the configuration jumper for the input to indicate the type of input used. Make sure the jumper is positioned correctly for each input, as follows:

○ ○ ○	VOLTS	JUMPERS
■ ○	THERM	
○ ■	4 – 20 MA	

Note: The default jumper setting is THERM (thermistor or dry contact).

Wiring digital outputs

You can wire digital outputs to the following DataNab modules:

- Ai8_R13 (direct and using an external relay)
- AiO8 (using a 12 volt DC external relay)

The Ai8_R13 has a single pole normally open contact built-in per output (total of 13). These can be used to switch low voltage loads directly or high voltage loads via an external relay.

To wire digital outputs:

1. Be sure the I/O module power is off before wiring any outputs.
2. To use the Ai8_R13 to drive low voltage loads without an external relay, connect the wiring as follows:



- To use the Ai8_R13 to drive high voltage loads (120VAC or greater), use an external load relay to separate the high voltage from the I/O module. Connect the wiring for driving a pump or heater as follows:

A8_R13 Output Connected to External Relay to Control a Pump

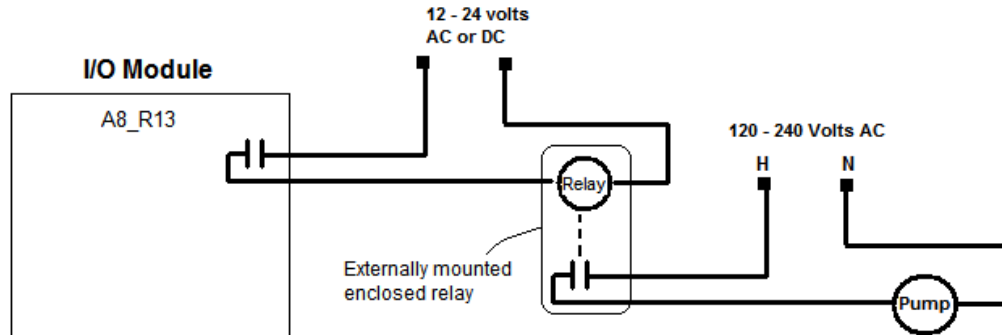

- An alternate method requires no 12-24 volts external volts for the coil. By using an RIB21CDC or similar relay (available from Kele at www.Kele.com), the 2 low voltage control wires can be connected directly to the contact output of the A8_R13. See the following diagram for using this method:

When using an external 12 volt DC relay, the energize voltage must be 10 volts or less. The coil impedance must be greater than 500 ohms.

An RIBTU1C (single pole double throw) or RIBTU2C (double pole double throw) relay is an ideal external relay for use with the AiO8 I/O module as it can handle loads of 10 amps resistive or 1/3 HP motor at 240 volts AC. Kele is a good source for this item at www.Kele.com.

Refer to the following figure:

Using an AiO8 analog output to drive a relay

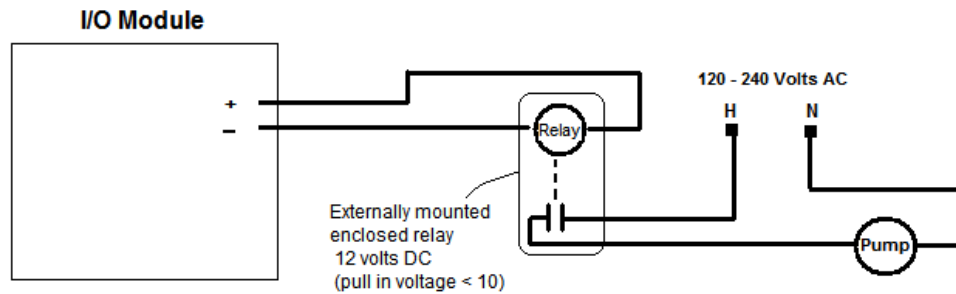

Note: You can manually override each output using the Hand-Off-Auto switches as follows:
Hand – Forces output to the ON state
Off – Forces output to the OFF state
Auto – Allows the output to follow the last command from the computer

Wiring analog outputs

You can wire analog outputs to the AiO8 DataNab module.

Use analog outputs to control proportional type devices such as a valve, a variable speed pump, or a damper.

Note: The standard analog output signal of an AiO8 I/O module is 0-10V. This signal can be converted to 0-20mA with an associated load resistor sized to provide 20mA at 10V.

To wire analog outputs:

1. Be sure the I/O module power is off before wiring any outputs.
2. Connect the output wiring as follows:

Typical Analog Output Connections

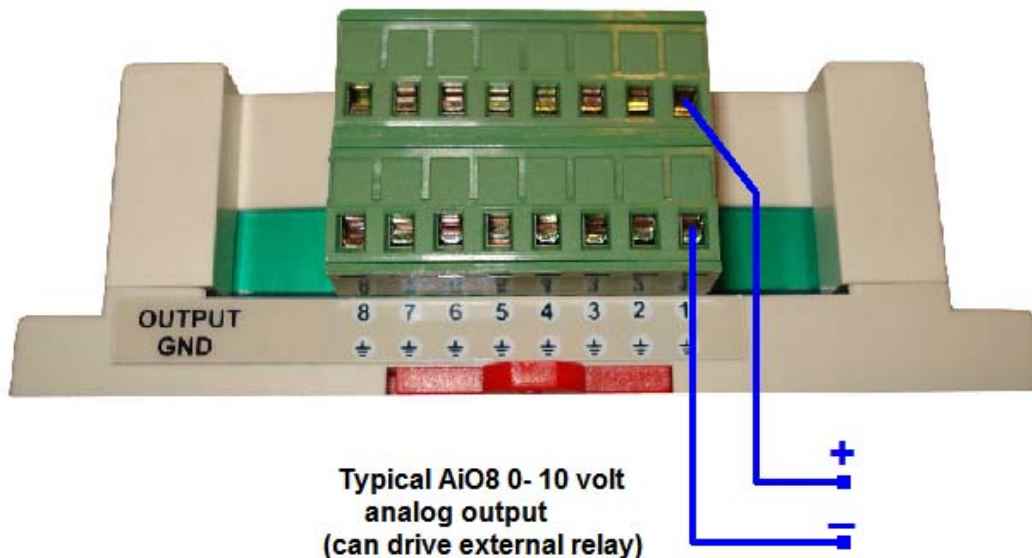
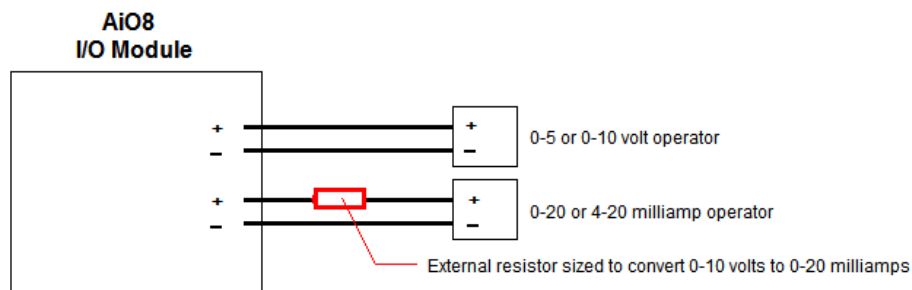

8 Supported Sensors and Control Devices

This section identifies the various sensors and control devices you can use with Climate Automation Systems' ENV climate control system.

Sensor/ Device	Description	Part Number	Source
I/O Module	Modbus module with 8 channel analog inputs and 13 relay outputs	Ai8_R13	http://www.datanab.com/controllers/Ai8_R13.htm
I/O Module	Modbus module with 8 channel analog inputs/ analog outputs	AiO8	http://www.datanab.com/controllers/AiO8.htm
I/O Module	Modbus module with 32 channel analog	Ai32	http://www.datanab.com/controllers/Ai32.htm
Communicating thermostat	Connects to, monitors, and controls an HVAC mechanical system	TR16-485 TR40	http://resconsys.com http://www.automatedoutlet.com/product.php?productid=221 or http://www.asihome.com/ASIShop/product_info.php?products_id=1291 or http://www.discounthomeautomation.com/cgi-bin/main/co_disp/displ/category_id/724/product_id/6925/RCS-Communicating-Thermostat-RS485
VLINX	Serial to Ethernet converter	esp901	http://www.bb-elec.com/product_family.asp?family_id=2
Temperature sensor	Provide precision remote temperature sensing	ST-R3 or ST-R3S or ST-R3R	http://www.kele.com/olcat/t1/10288.html
Humidity sensors	Measure relative humidity from 0% to 100%	KHD or KHO or KHR	http://www.kele.com/olcat/h2/10820.html
Immersion sensor	Provides precision remote temperature sensing	ST-W3E-XHP	http://www.kele.com/olcat/t1/10297.html
Duct temperature sensor	Temperature sensor for duct mounting	KTD3	http://www.kele.com
Thermal conducting compound	Facilitates heat transfer between mating surfaces	TCC-111	http://www.kele.com

Thermocouple probe	High pressure sensors for mounted NPT security	TC-NPT	http://www.omega.com/ppt/pptsc.asp?ref=TC-NPT
Thermocouple with protection head	Industrial thermocouples with protection heads	Various	http://www.omega.com/ppt/pptsc.asp?ref=NB1-ICIN_INDUST_TC
Temperature transmitters	Converts thermocouple or RTD signals into a 4 to 20 mA dc signal output	TX90A Series	http://www.omega.com/ppt/pptsc.asp?ref=TX91A_92A&Nav=temn01
Variable speed controller	Controls most single phase AC pumps and motors	PSC-1	http://www.innovextechnologies.com/pdf/iWorX%20PSC-1%20User%20Guide.pdf
Humidity transmitters	Provides precision humidity measurement	GEH Series	http://www.kele.com/olcat/h2/11033.html
KWH meter	Provides active electricity measuring	EKM-25IDS	http://kwhmeters.com/EKM_Metering/Basic_Pass-through_Meters.html
KWH meter	KWH monitoring for a 120vac load	EKM-15E	http://kwhmeters.com/EKM_Metering/120V_External_CT_Meter.html
Multi-voltage relay modules	Remote relays for control or status feedback	PAM-1 or PAM-4	http://www.kele.com/olcat/rc15/10217.html